

**LINEAR TRACE  
PROGRAMMABLE PLAY / QUARTZ LOCK  
DIRECT DRIVE TURNTABLE SYSTEM**

# **MODEL NO. LP-3000K**



OPERATING INSTRUCTIONS

**AIWA<sup>®</sup>**

## FEATURES

- **Highly dependable rack screw drive system (single support) tonearm**  
This is a rigid and reliable system which employs a light-inertia coreless motor and which features sound-proofing.  
The drive screw, which is finished to a high level of precision, and the low-friction, high-precision bearings combine to yield a highly accurate and stable feed operation. In addition, the single support system helps to suppress vibrations which have an adverse effect on the tonearm. Using a photoelectric (photo transistor) system, the angle of the tonearm is detected extremely accurately. (Less than 1/4 of one degree of the detection angle).
- **Highly rigid linear tonearm**  
This tonearm allows the angle with the stylus tip in the record groove to be kept at exactly 90 degrees for a tracking error which borders on zero. At the same time, however, there is no inside force. This is why there is no lack of balance in the left and right channel tracking force. Another feature is that the tonearm is completely symmetrical and this contributes toward maintaining a perfect lateral balance.  
The length of the tonearm pipe has been shortened and its coupling with the housing (bearing section) reinforced to prevent the generation of resonance due to torsion and bending.  
Diecast zinc is used for the center housing base to increase the mass and safeguard against external vibration.
- **Programmable, fully automatic mechanism with built-in micro-computer**  
The built-in microcomputer allows up to 15 tracks on an LP to be selected at random for play. All you have to do is simply prepare the program by pressing lightly on the front panel buttons, and the tracks are played for you in order.

## CAUTIONS FOR OPERATION

Bear in mind the following points. Heeding the recommendations will allow this turntable to display its performance to the full.

1. You will not be able to derive the most in performance from the turntable if it is not completely level. Make absolutely sure that it is on the horizontal.

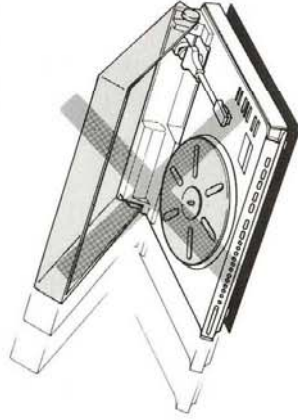

2. Use a soft brush to remove dust from the stylus tip. Do not touch the stylus or apply any pressure to it.

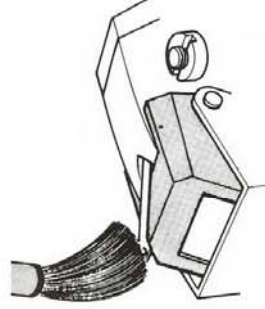

4. Do not install the turntable where it will be exposed to direct sunlight, or temperature extremes. (The optimum usable temperature range is +5°C to +35°C.)



3. In order to prevent acoustic feedback, install the turntable as far away from the speakers as possible. Avoid installing it on top of the speakers.

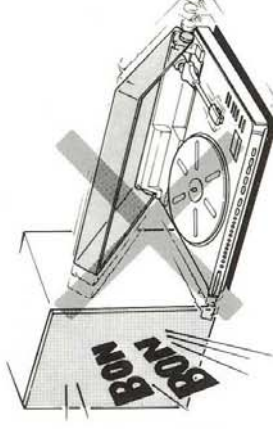

6. Do not attempt to force the tonearm.

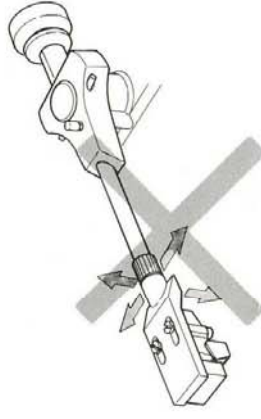

- **Detection mechanism with disc sensor**

The detection unit, composed of an infrared ray LED with a high resolution and a photo transistor, plus a disc sensor based on a data processing unit employing light-changing principles unaffected by extraneous light, perform four useful functions. They detect whether or not a disc is on the platter, the size of the disc, the position between tracks and the position where the stylus descends onto the disc.

- **Repeat play mechanism**

The same track or part of a record can be played repeatedly up to a maximum of ten times when the number of repetitions is designated. When this number is not designated, repeat play will be performed up to 24 times.

- **Diecast zinc platter with 500 kg-cm<sup>2</sup> moment of inertia**  
Diecast zinc, having superior characteristics, is used as the material for the platter. This unit features a high inertia moment of 500 kg-cm<sup>2</sup>. This is why there is no rise in the sound and why distortion is reduced to the bare minimum. An extra bonus is the fact that the wow/flutter response is further reduced.
- **Pitch control-equipped quartz PLL servomotor**  
A quartz PLL servomotor with minimal load fluctuations and drift is employed. Also provided is a pitch control which allows the pitch to be varied in 0.1% steps with the quartz lock engaged up to a maximum of 6% faster or slower than the rated speed.
- **Feather-touch control buttons**
- **Remote control terminal (remote control unit is available at an option) for operation at a distance from the turntable**
- **Front panel controls for operation even with the dust cover lowered.**
- **Synchro operation function for starting and stopping the turntable and an AIWA cassette deck (AD-6900, AD-6700) simultaneously when recording.**

## AC Voltage Selector Switch

This model has been preset to operate on a 240V power source voltage. However, it can be set to work on power source voltages of 100V, 120V and 220 V. When changing the power source voltage setting, set the power source voltage selector switch to the position corresponding to the power source voltage of your area.



**NAMES OF THE PARTS**

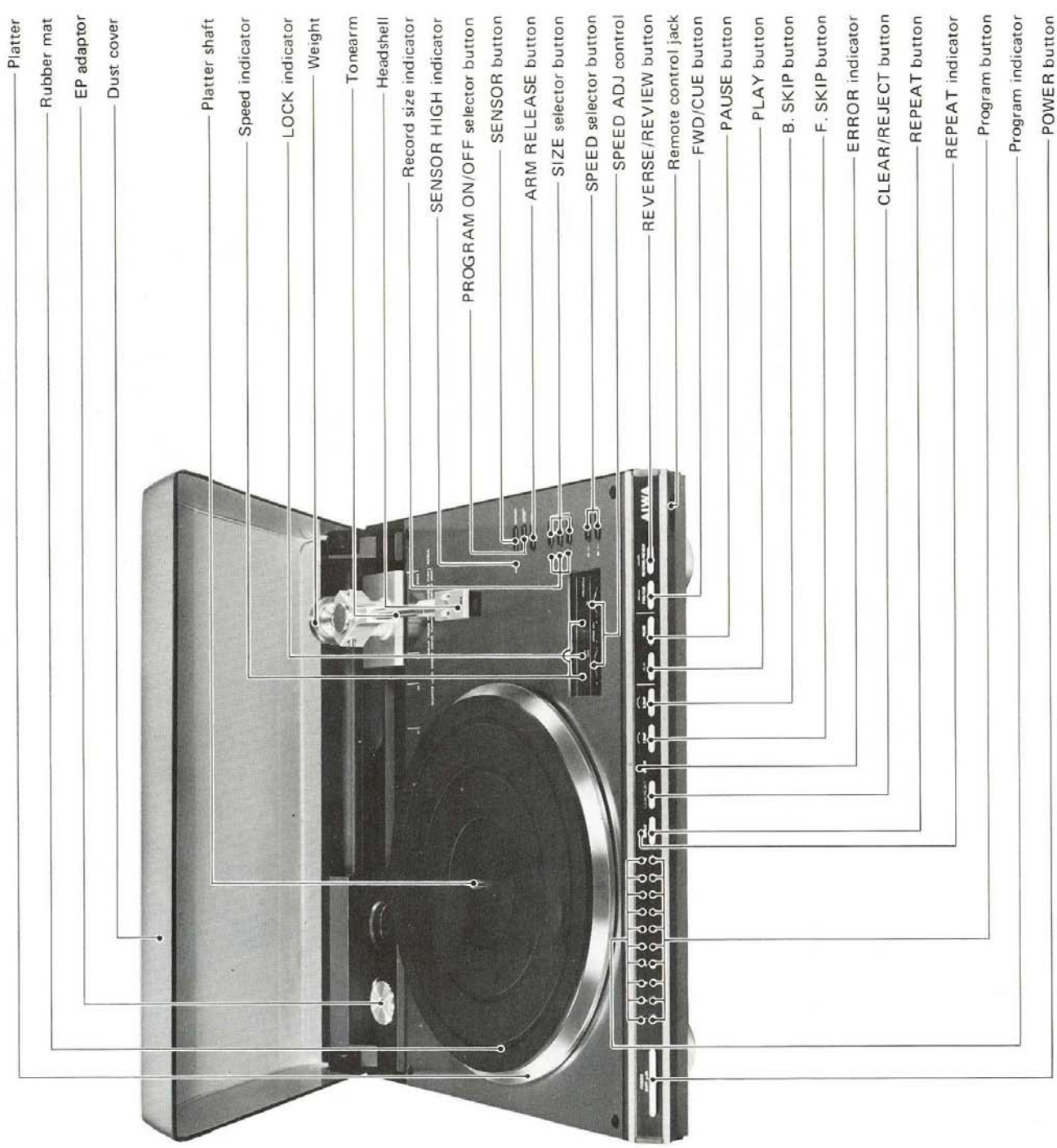

- Platter
- Rubber mat
- EP adaptor
- Dust cover
- Platter shaft
- Speed indicator
- LOCK indicator
- Weight
- Tonearm
- Headshell
- Record size indicator
- SENSOR HIGH indicator
- PROGRAM ON/OFF selector button
- SENSOR button
- ARM RELEASE button
- SIZE selector button
- SPEED selector button
- SPEED ADJ control
- REVERSE/REVIEW button
- Remote control jack
- FWD/CUE button
- PAUSE button
- PLAY button
- B. SKIP button
- F. SKIP button
- ERROR indicator
- CLEAR/REJECT button
- REPEAT button
- REPEAT indicator
- Program button
- Program indicator
- POWER button

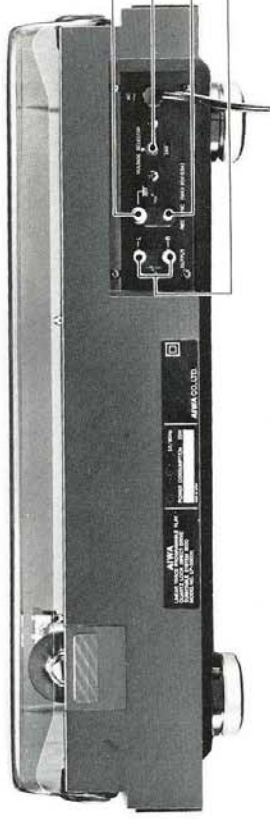

- Ground terminal
- VOLTAGE SELECTOR switch
- REC SYNC jack
- OUTPUT jacks

## ASSEMBLY

In order to safeguard against damage resulting from vibration or shock sustained during transportation, the platter, rubber mat, EP adaptor, sub weight, weight and headshell are packed separately. Assemble them correctly as outlined below.

### Removal of transit screw

Remove the transit screw which can be found underneath the turntable.

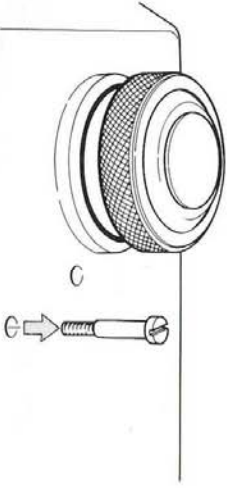

### Mounting the platter and rubber mat

Unpack the platter and rubber mat which have been packed separately, slip the platter over the platter shaft and then the rubber mat over the platter.

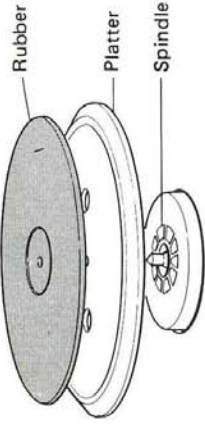

### Mounting the weight and sub weight

Mount the weight and sub weight first on the tonearm before attaching the headshell.

1. Remove the cover for mounting the weight at the rear of the turntable.

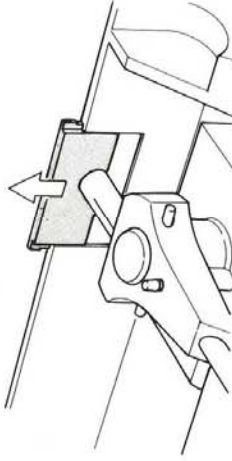

2. Lower the end of the tonearm (the end to which the headshell is attached) slightly, and slip the weight over the end of the tonearm. Rotate it in the direction indicated by the arrow and then slide it forward until it will go not further.

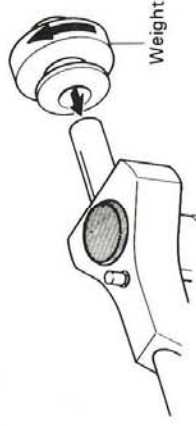

3. Attach the sub weight at the end of the tonearm.

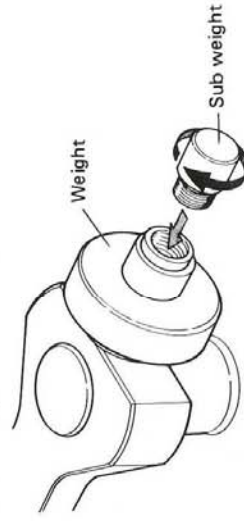

### Mounting the dust cover

With the dust cover placed as shown in the figure below, slot the metal fittings into the grooves at the side of the turntable.

- Do not force the dust cover into place.

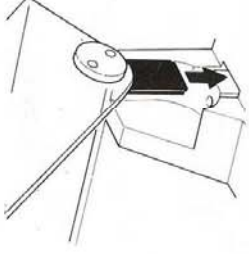

### Mounting the cartridge and headshell

1. Wire the headshell and the cartridge as illustrated in the figure.

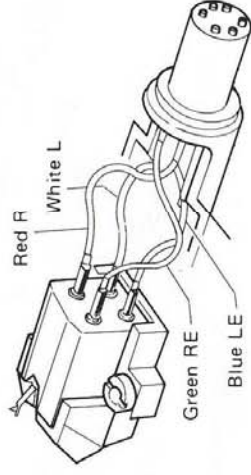

2. Adjust the height of the stylus so that it resembles that in the figure using the accessory spacers. There are three spacers: their thicknesses are 2 mm, 1 mm and 0.5 mm. Use them in combination.

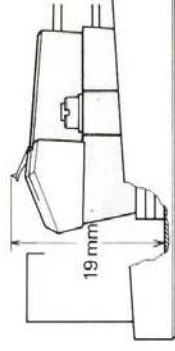

(Example)

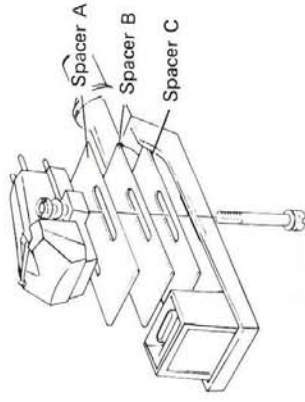

3. Insert a new stylus and use the accessory stylus tip position adjustor to adjust the stylus tip to the center of the cross mark.

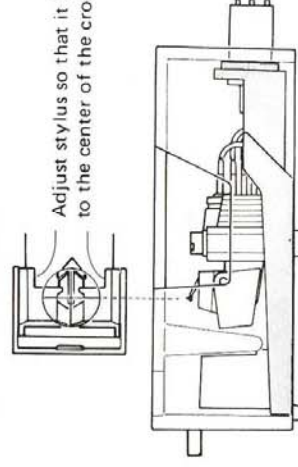

- Attach the headshell to the tonearm.

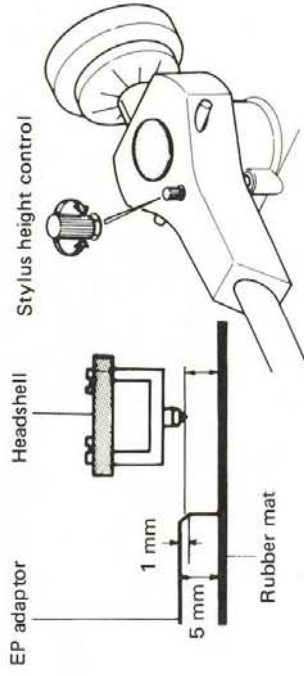

- Check that the stylus tip is positioned 4.5 mm above the rubber mat. To do this, depress the PLAY button and when the stylus moves toward the platter, set the POWER button to OFF. Use the EP adaptor to check the height as illustrated in the figure. If the height is not correct, rotate the stylus height control and adjust.

### EP Adaptor

Place the EP adaptor into its designated well on the top of the turntable.

## ADJUSTMENTS

### Adjusting the Horizontal Position

Acoustic cabinet insulators located at the four bottom corners of the cabinet should be adjusted up or down to make the turntable level.

Before attempting to make adjustments, loosen the insulators two or three turns to the left, and then turn the insulators right or left so that the turntable is set in a stable, horizontal position.

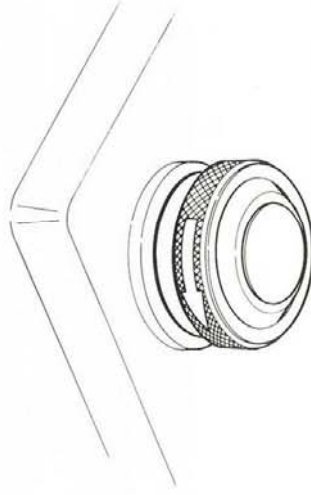

## ADJUSTING THE TRACKING FORCE

- Check first that the transit screw has been removed.
- Raise the stylus cover.

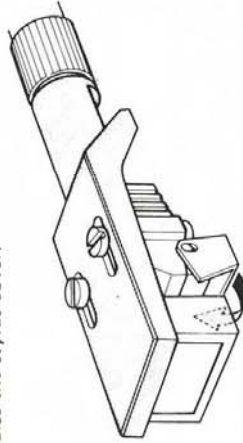

- Set the POWER button to the ON position.

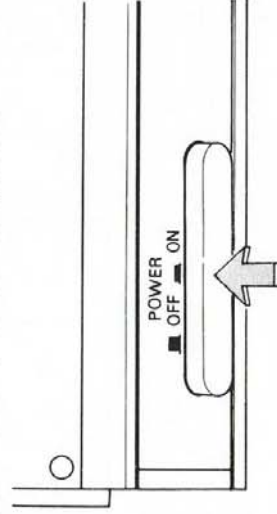

- Depress the ARM RELEASE button.

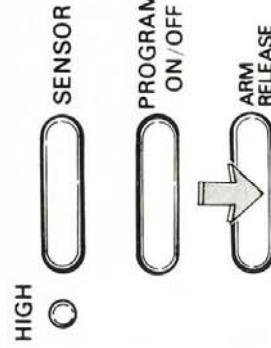

- Rotate the weight either clockwise or counterclockwise and adjust until the tonearm is balanced horizontally.

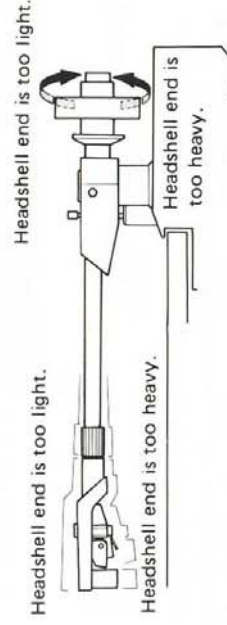

- If the tonearm cannot be balanced properly because the headshell and cartridge are too light or too heavy, move the ring weight to the fore or to the rear, and re-adjust. If the tonearm still cannot be balanced properly, rotate the sub weight mounted on the rear of the tonearm to the left, remove it and then re-adjust.

Range over which weight can be adjusted.

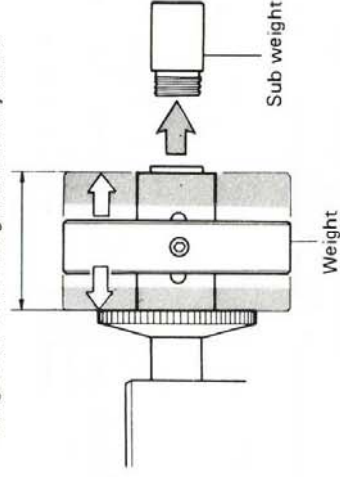



5. Rotate the tracking force counter ring only and set the '0' marking to the index line.

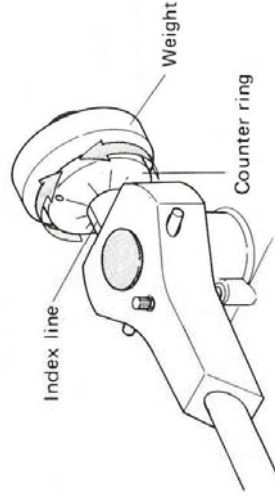

6. Set the stylus pressure to match requirements of your cartridge by turning the stylus pressure adjustment knob.

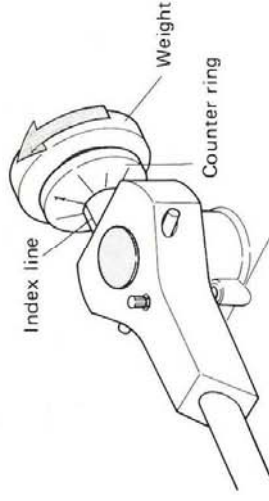

## CONNECTIONS WITH STEREO AMPLIFIER

The cartridge which comes with this turntable is a moving magnet (MM) type. Use the stereo pin cords to connect the PHONO (MM) jacks on the stereo amplifier with the OUTPUT jacks on the turntable. Connect the channels properly (L to L and R to R).

- Make sure that the ground terminal on the turntable and that on the stereo amplifier are connected with the ground wire.

### CAUTION:

Do not connect an excessive capacitance to the PHONO jacks on the amplifier. If the amplifier is provided with an input capacitance selector, adjust it to around the 100pF mark.

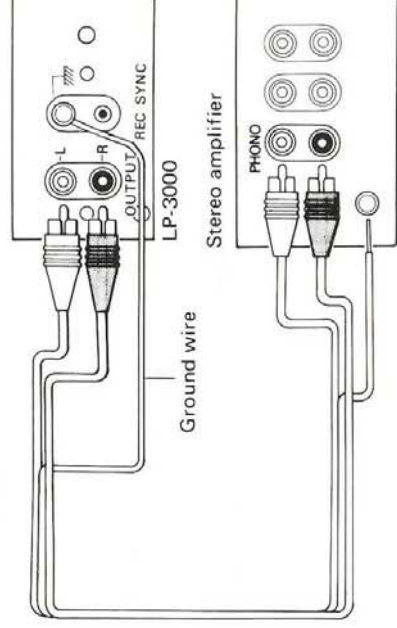

## FINE SPEED ADJUSTMENTS

The rotational speeds of the platter (33-1/3, 45 rpm) are displayed digitally, and when the rated speed (33-1/3, 45 rpm) is varied in steps of  $\pm 0.1\%$ , this fine adjustment is also displayed digitally. Say, for instance, you want to listen to a record at 3% faster than the rated speed. In cases like this, rotate the fine control to the + side until +3.0 is registered on the display.

The platter speed can be adjusted before actual play. When the platter rotates and reaches the preset speed, the quartz lock mechanism engages, and the lock indicator comes on.

## ERROR INDICATOR

The error indicator winks when an error is made in operating the unit. If the indicator continues to wink, first depress the clear/reject button, read through the operating instructions and operate the unit correctly.

## RECORD PLAY

### Programming

- Make sure that you use the headshell with the accessory sensor. If you decide to use another headshell, you will not be able to program the record play.
1. Depress the POWER button and supply power to the turntable. (Check that the PROGRAM ON indicator has come on. If you find that the PROGRAM OFF indicator has come on instead, depress the PROGRAM button and cause the PROGRAM ON indicator to come on.)
  2. Depress the program buttons in the order in which you want the tracks on the disc played. Up to 15 tracks can be programmed. If the tracks are not programmed, play will start from the first track and then proceed in order across the disc.

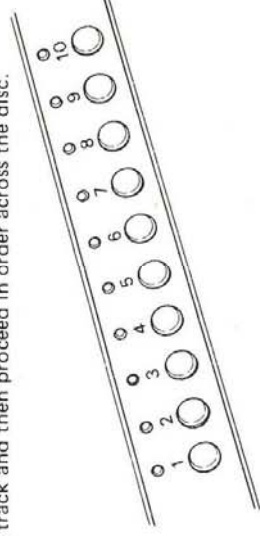
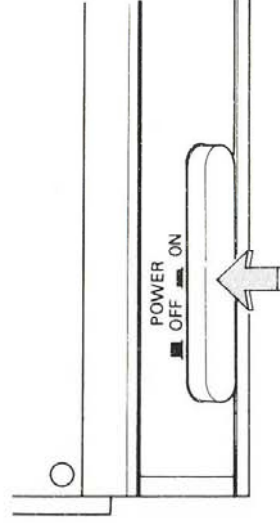

3. For repeat play, depress the REPEAT button, and depress the program button the number of times you want the play repeated. If you depress the REPEAT button, the play will be repeated 24 times or until stopped manually.

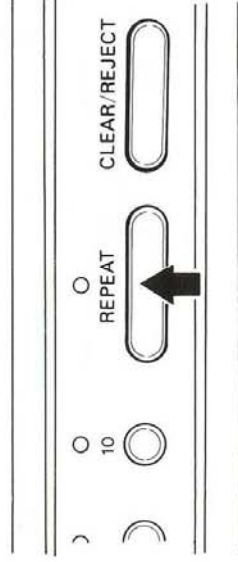

4. Depress the SPEED selector button in accordance with the speed at which the disc is meant to be played.

5. Depress the PLAY button. The tonearm moves above the disc to the spot corresponding to the first programmed track, it then descends onto the record, and the track is played.

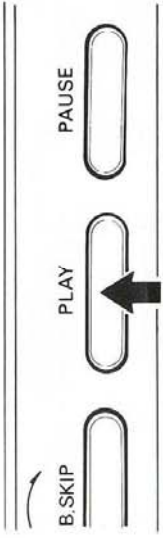

6. When all the programmed tracks have been played, the tonearm rises and returns to the START position.

\* To designate more than 10 tracks on one side of a disc, depress memory button "10" and depress any other memory button from 1 through 9 at the same time. The track which is the sum of these two buttons' numbers is then designated. To designate further tracks after the tenth track in succession, release all ten program buttons, and then program the tracks again.

\* Refer to the table on page 9 for the operations of each of the control buttons during programmed play.

### Example of program

To listen to tracks 2, 12, 6, 13 and 5 on a record:

1. Depress the POWER button and set it to ON. (Check that the PROGRAM ON indicator has come on.)
  2. Depress the memory buttons in the order of 2, 12, 6, 13 and 5. To memorize 12 and 13, simply depress the number 10 button and the number 2 or 3 memory button together.
  3. Depress the PLAY button.
  4. The tracks are now played in the order of 2, 12, 6, 13 and 5.
- \* If you want to add another track for your listening enjoyment during play, depress the program button whose number corresponds to the number of the track. You cannot do this, however, if you have already programmed 15 tracks in your program, or if you are playing a record without the memory function.

\* For repeat play, depress the REPEAT button and also the memory button the number of times that corresponds to the number of repeats. If only the REPEAT button is depressed, play will be repeated 24 times or until stopped manually.

### CAUTION

- You cannot add tracks to the memory with a number greater than 10.
- When programming an additional track or tracks, the indicator will not indicate that the program button has been depressed for the additional program.
- There is no indication of the number of repeats.

### CAUTION:

• This turntable uses infrared rays to detect the absence of sound grooves on a disc. Because of the way this system is designed to work, there may be malfunctions with the following types of records.

- \* All records which are not black.
  - \* Records with very narrow portions between the tracks where no sound is recorded.
  - \* Records with a pronounced discrepancy in a track between the cutting levels.
  - \* Records which are badly warped.
- If you want to hear the tracks on records like these (and it is also possible that there may be other malfunctions), use the turntable as a fully automatic record player.
- If the width of the tracks on the record are less than 3 mm, the turntable may malfunction. In particular, the first track of the B. SKIP function may not operate.
- If a strong light is suddenly shined onto the sensor section the turntable may malfunction.
  - The turntable may also malfunction if the F. SKIP (forward skipping) button or the B. SKIP (backward skipping) button is repeatedly depressed near the last sound groove on the disc. In the case of a malfunction, release using the CLEAR/REJECT button.
  - If a strong light is suddenly shined onto the sensor section during programmed play, the turntable may malfunction.
  - No revisions can be made to the contents of the program. If you want to revise the program, depress the CLEAR/REJECT button, check that the tonearm is at the START position and then re-program the play.



## USE AS A FULLY AUTOMATIC TURNTABLE

1. Depress the POWER button and supply power to the turntable.

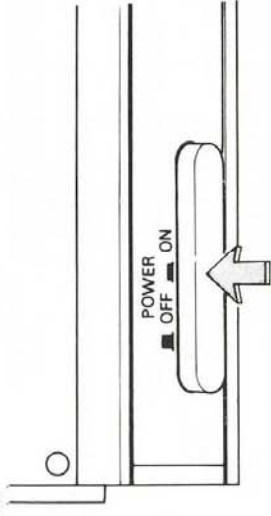

2. Depress the PROGRAM button. Check that the PROGRAM OFF indicator has come on.
  - \* When using a headshell other than that which is supplied with the turntable, the PROGRAM OFF mode is set automatically.

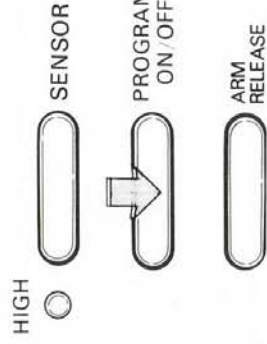

3. Depress the record SIZE button corresponding to the size of the record.

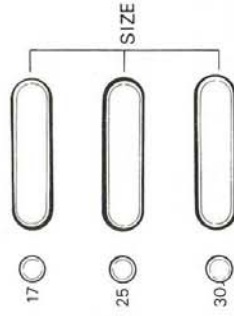

4. Depress the SPEED selector button corresponding to the rated speed of the record.

5. For repeat play, depress the REPEAT button and also the memory button corresponding to the number of times you want the play repeated. If only the REPEAT button is depressed, the same program will be played 24 times or until stopped manually.

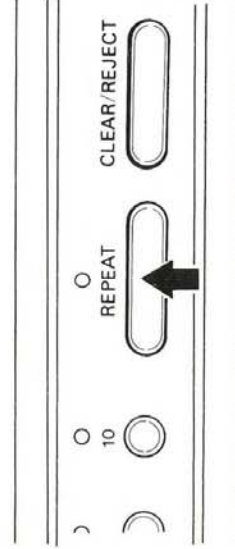

6. Depress the PLAY button. The tonearm will move across the record and descend. Play will then begin.

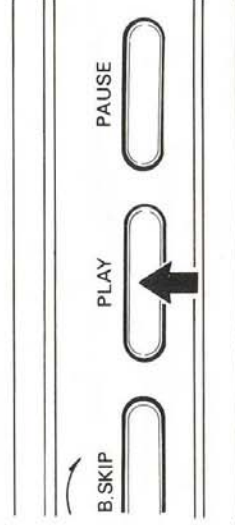

7. When play has finished, the tonearm automatically rises and returns to its original position.
  - \* Refer to the table on page 9 for the operations of the control buttons when the turntable is set to the fully automatic operation mode.

### CAUTION

- If you select by mistake a record size which is actually larger than the record you intend to play, the stylus will descend onto the rubber mat instead and it may be damaged.
- If a 30 cm or 25 cm record is placed on the platter and the 17 cm record size selected, the end of the record will not be detected. This is because the location for the detection of the last sound groove on the record is different and it does not indicate that anything is wrong with the turntable.



## OPERATIONS OF THE CONTROL BUTTONS

	Programmed play		Fully automatic turntable
	With memory	Without memory	
<b>Program buttons</b>	These can be used to memorize up to 15 tracks. The numbers of the tracks which can be memorized range from 1 through 19.		The error indicator winks.
<b>REPEAT button</b>	Depress this for repeat play. To designate the number of times play is to be repeated, depress this button and at the same time depress the program buttons for the corresponding number of times. You can thereby freely select the number of repeats up to 10 times. If this number is not designated, the same tracks will be repeated a total of 24 times or until stopped manually. Depress this button again to release this function.		
<b>CLEAR/REJECT button</b>	All the contents of the program are erased and the tonearm returns to the START position.		The tonearm returns to the START position. Repeat play is also released.
<b>F. SKIP (forward skipping) button</b>	The tonearm advances to the next track which has been programmed.	Play is interrupted and the next track is played. If the stylus rises in the PAUSE mode, the turntable will be set to the PAUSE mode at the start of the next track.	Cannot be used. The F. SKIP function does not work.
<b>B. SKIP (backward skipping) button</b>	The tonearm is returned to play from the start of the track being played.	Play is interrupted, the tonearm moves to the start of the track which has been played, and the same track is played. If the turntable is set to the PAUSE mode, the tonearm will move to the start of the track which has just been played and the turntable will be set to the PAUSE mode.	Cannot be used.
<b>PLAY button</b>	If the tonearm is in the START position, it will move to the first track which has been memorized and play will begin. If the turntable is set to the PAUSE mode, this mode will be released and play will begin.	If the tonearm is in the START position, it will move to the first track which has been memorized and play will begin. If the turntable is set to the PAUSE mode, this mode will be released and play will begin.	Select the record size before depressing this button. If this button is depressed after you have selected the record size, the tonearm will move to the first track on the record and play will begin. If the turntable is set to the PAUSE mode, this mode will be released and play will begin.
<b>PAUSE button</b>	If this is depressed during play, the tonearm will rise, play will be interrupted and the turntable will be set to the PAUSE mode.	If this is depressed during play, the tonearm will rise, play will be interrupted and the turntable will be set to the PAUSE mode. If the tonearm is moving across the record, this movement will cease, and the turntable will be set to the PAUSE mode.	
<b>FWD/CUE button</b>	This does not work. If this button is depressed, the error indicator will come on.	If the tonearm is in the START position or PAUSE mode, it will continue to move across the disc. Operate the PAUSE or PLAY button while it is moving. During play, the tonearm will rise and advance at low speed, and when the button is released, play will start. When the tonearm advances to the end of the final track, the end of the record is detected, and it will return to the START position even if you release the button.	If the tonearm is in the START position, the error and record size indicators wink. If the record size is designated, operation will be the same as programmed play if the memory is not used.
<b>REVERSE/REVIEW button</b>	This does not work. When this button is depressed, the error indicator winks.	Depressing this button reverses the tonearm at low speed during play. If the tonearm is set to the PAUSE mode, it continues to reverse at high speed and it returns to the START position. Operate the PAUSE or PLAY button while the tonearm is being reversed. If the tonearm is at the START position, it will not move.	
<b>SENSOR button</b>	This button need not normally be operated. Set it to HIGH when the intervals between the tracks on a disc are not detected since this will increase the sensor's sensitivity.		
<b>PROGRAM ON/OFF button</b>	This button is used to select programmed play and fully automatic play. Set so that the PROGRAM ON indicator comes on.		Set the button so that the PROGRAM OFF indicator comes on.

## SYNCHRO OPERATION FUNCTION

If you connect this turntable with an AIWA cassette deck or stereo system provided with a PLAYER SYNC jack, you will be able to record music as soon as the tonearm descends onto the record. This is what AIWA calls "synchro operation".

If this cassette deck is equipped with plunger-type logic controls (as on the AIWA AD-6900 or AD-6700) the synchro-operation can be stopped and started repeatedly.

- **Connections to a stereo cassette receiver (AF-3090, etc.)**
  - 1) Connect the PLAYER SYNC jack on the stereo cassette receiver with the REC SYNC jack on the turntable using the accessory cord.
  - 2) Now depress the PHONO selector button on the stereo cassette receiver and set the deck to the recording mode. (The mechanism is now actuated, the deck is set to the pause mode, and the tape does not move.)
  - 3) When the turntable is set to the play mode, the tape starts to move and recording starts as soon as the tonearm descends onto the record.
  - 4) As soon as the record has been played and the tonearm rises, the tape stops and the deck is set to the pause mode.
- **Connections to a cassette deck (AD-6600, etc.)**
  - 1) Connect the PLAYER SYNC jack on the cassette deck with the REC SYNC jack on the turntable using the accessory cord.
  - 2) Depress the PAUSE key of the cassette deck and set the deck to the pause mode. Now depress the RECORD and FWD (play) keys and set the deck to the recording mode.
  - 3) As soon as the turntable is set to the play mode and the tonearm descends onto the record, the deck's PAUSE key is released and recording starts.
- The RECORD key on an Aiwa cassette deck with a PLAYER SYNC jack has a mechanism which locks independently. You'll find it handier to actuate the synchronized function after you have locked the RECORD key and adjusted the recording level.
- **Connections to a portable stereo (TPR-950, etc.)**
  - 1) Connect the PLAYER SYNC jack on the portable stereo with the REC SYNC jack on the turntable using the accessory cord. (The REMOTE jack on the portable will also do.)
  - 2) Set the portable stereo to the recording mode. (The remote switch is actuated and the tape does not move.)
  - 3) When the turntable is set to the play mode and the tonearm descends onto the record, the recording starts.

## REMOTE CONTROL OPERATION

You can operate the turntable from a distance if you connect the optional RC-20 remote control unit to the remote control jack. When connecting this control unit, open the lid, as shown in the figure, and proceed to connect. For details, refer to the operating instructions booklet that comes with the remote control unit.

4) As soon as the record has been played and the tonearm rises, the remote switch is actuated and the portable stereo is set to the pause mode.

- When connecting to the REMOTE jack, remember that the remote switch will be actuated when the cord is connected, so always disconnect it except when recording off records.

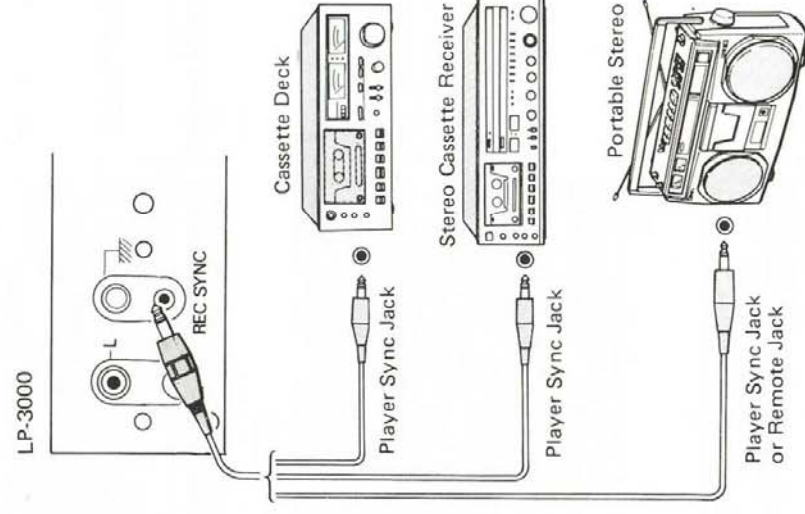



## WHEN USING ANOTHER CARTRIDGE AND HEADSHELL

The turntable is automatically set to the fully automatic mode when another headshell is used.

1. Wire the headshell and the cartridge as illustrated in the figure.

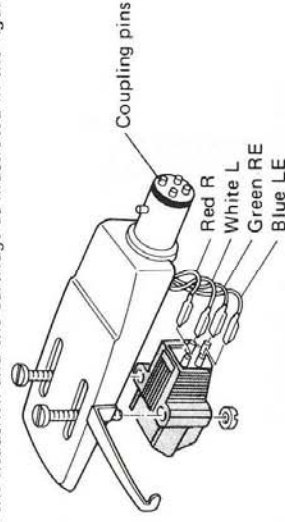

2. Mount the stylus so that its position resembles that shown in the figure.

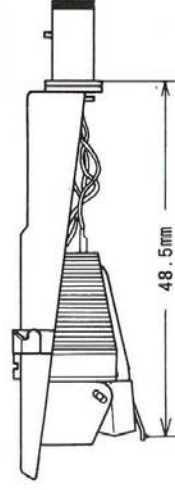

3. Mount the headshell onto the tonearm.
4. Check that the stylus tip is positioned 4.5 mm above the rubber mat. To do this, depress the PLAY button and when the stylus moves toward the platter, set the POWER button to OFF. Use the EP adapter to check the height as illustrated in the figure. If the height is not correct, rotate the stylus height control and adjust.

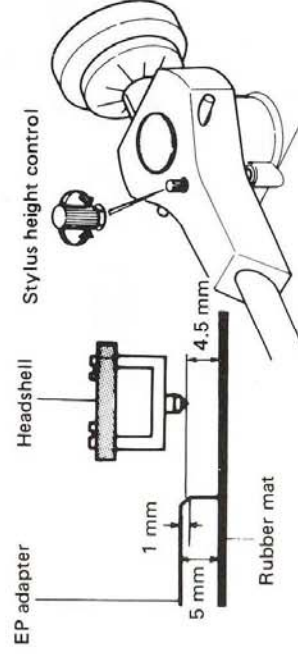

### CAUTION

You will not be able to use a headshell with coupling pins having a larger diameter than those compatible with the tonearm.

## SPECIFICATIONS

<b>Type:</b>	Linear trace programmable direct drive quartz lock turntable
<b>Semiconductors:</b>	1 LSI, 23 ICs, 54 transistors, 60 diodes, 24 LEDs, 5 numerical display LEDs
<b>Power requirements:</b>	AC 100 V/120 V/220 V/240 V switchable, 50/60 Hz
<b>Power consumption:</b>	20 W
<b>Dimensions:</b>	480 (W) x 150 (H) x 439 (D) mm
<b>Weight:</b>	15.2 kg
<b>&lt;Platter section&gt;</b>	
<b>Drive system:</b>	Direct drive
<b>Drive motor:</b>	Pulse synthesizer quartz PLL servo DD motor
<b>Control system:</b>	Quartz PLL servo
<b>Start-up torque:</b>	Over 750 g·cm
<b>Speeds:</b>	33-1/3, 45 rpm
<b>Fine speed adjustment:</b>	Quartz pitch control (digital display), adjustable in 0.1% steps up to ±6%
<b>Braking mechanism:</b>	All-electronic brake
<b>Platter:</b>	Zinc diecast (310 mm diameter, 3.2 kg weight)
<b>Moment of inertia:</b>	500 kg·cm <sup>2</sup> (including rubber mat)
<b>Wow/flutter:</b>	0.025% WRMS, 0.038% (DIN)
<b>SN ratio:</b>	75 dB (DIN-B), 60 dB (IEC-B)

### <Tonearm section>

<b>Type:</b>	Linear tracking, static balanced tonearm
<b>Effective length:</b>	182 mm
<b>Rotating shaft sensitivity:</b>	30 mg initial dynamic horizontal, vertical sensitivity
<b>Applicable tracking force:</b>	0 to 3 g (direct readout of tracking force)
<b>Suitable cartridge &amp; headshell weight:</b>	4 to 15 g (with accessory headshell, sub weight) 18 to 29 g (with other headshell, sub weight) 13 to 24 g (with other headshell, no sub weight)
<b>Headshell weight:</b>	*Spacers weigh about 1.5 g per 1 mm thickness
<b>Output cords:</b>	16.5 g aluminum diecast Low-capacitance, gold-plated cords (1.5 m) with pin plugs

\*Specifications and external appearance are subject to change without notice due to product improvement.

### IMPORTANT

The wires in this mains lead are coloured in accordance with the following code:

Blue: Neutral  
Brown: Live

As the colours of the wires in the mains lead of this apparatus may not correspond with the coloured markings identifying the terminals in your plug proceed as follows.

The wire which is coloured blue must be connected to the terminal which is marked with the letter N or coloured black.

The wire which is coloured brown must be connected to the terminal which is marked with the letter L or coloured red.

# AIWACO.,LTD.



# REMOTE CONTROL UNIT RC-20

## OPERATING INSTRUCTIONS

You can operate the turntable from a distance if you connect the RC-20 remote control unit to the remote control jack.

### OPERATIONS OF THE CONTROL BUTTONS

	Programmed play		Fully automatic turntable
	With memory	Without memory	
<b>CLEAR/REJECT button</b>	All the contents of the program are erased and the tonearm returns to the START position.	The tonearm returns to the START position. Repeat play is also released.	
<b>F. SKIP (forward skipping) button</b>	The tonearm advances to the next track which has been programmed.	Play is interrupted and the next track is played. If the stylus rises in the PAUSE mode, the turntable will be set to the PAUSE mode at the start of the next track.	Cannot be used. The F. SKIP function does not work.
<b>B. SKIP (backward skipping) button</b>	The tonearm is returned to play from the start of the track being played.	Play is interrupted, the tonearm moves to the start of the track which has been played, and the same track is played. If the turntable is set to the PAUSE mode, the tonearm will move to the start of the track which has just been played and the turntable will be set to the PAUSE mode.	Cannot be used.
<b>PLAY button</b>	If the tonearm is in the START position, it will move to the first track which has been memorized and play will begin. If the turntable is set to the PAUSE mode, this mode will be released and play will begin.	If the tonearm is in the START position, it will move to the first track which has been memorized and play will begin. If the turntable is set to the PAUSE mode, this mode will be released and play will begin.	Select the record size before depressing this button. If this button is depressed after you have selected the record size, the tonearm will move to the first track on the record and play will begin. If the turntable is set to the PAUSE mode, this mode will be released and play will begin.
<b>PAUSE button</b>	If this is depressed during play, the tonearm will rise, play will be interrupted and the turntable will be set to the PAUSE mode.	If this is depressed during play, the tonearm will rise, play will be interrupted and the turntable will be set to the PAUSE mode. If the tonearm is moving across the record, this movement will cease, and the turntable will be set to the PAUSE mode.	
<b>FWD/CUE button</b>	This does not work. If this button is depressed, the error indicator will come on.	If the tonearm is in the START position or PAUSE mode, it will continue to move across the disc. Operate the PAUSE or PLAY button while it is moving. During play, the tonearm will rise and advance at low speed, and when the button is released, play will start. When the tonearm advances to the end of the final track, the end of the record is detected, and it will return to the START position even if you release the button.	If the tonearm is in the START position, the error and record size indicators wink. If the record size is designated, operation will be the same as programmed play if the memory is not used.
<b>REVERSE/REVIEW button</b>	This does not work. When this button is depressed, the error indicator winks.	Depressing this button reverses the tonearm at low speed during play. If the tonearm is set to the PAUSE mode, it continues to reverse at high speed and it returns to the START position. Operate the PAUSE or PLAY button while the tonearm is being reversed. If the tonearm is at the START position, it will not move.	

# AIWA CO.,LTD.

# CONNECTION OF OTHER TYPES OF CARTRIDGES

Because this turntable is capable of detecting the record's presence or the blank segments between entries on the disc, precise adjustment of the distance between the platter and the sensor is essential. If other types of cartridges are employed, use the spacers provided to create the proper gap.

Please refer to Page 4 in the owner's manual for further reference concerning adjustment.

- When connecting the cartridge to the headshell, insert the spacer(s) to create the proper distance as shown in the picture below.

The width of the spacers are 2 mm (A) 1 mm (B) and 0.5 mm (C) respectively.

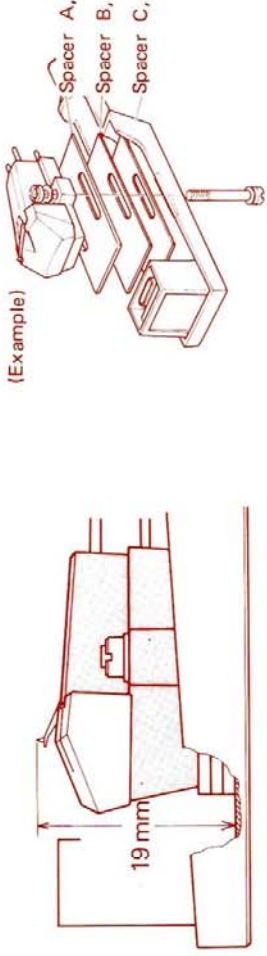

- The recommended spacer(s) for use with major cartridge types is indicated in the chart below:

Manufacturer	Type	Spacers
ADC	QLM, XLM, VLM series	(B)
AKG	P6, P7, P8 series	(C)
Ortofon	F-15M-20 MC-20, SL-20	(A + A or A + A + C) (B)
SHURE	M95	(A)
	V15TYPE IV *	(A)
	V15TYPE III	(B + C)
PIKERING	All #	(None)
SATIN	M-117, M-18	(C)
	M-14	(A)
SONY	XL-45	(B)
TECHNICS	205C series	(B)
DENON	DL-103	(A + B + C)
	DL-109	(A)
GRACE	F-8 series	(C)
	F-9 series	(A + C)
AUDIO TECHNICA	AT-15, 20 *	(B)
MICRO	LC-40	(A + B)
F R	FR-1 series	(B + C)
PIONEER	PC-1000/II	(B)

- Items with the "\*" indication can be employed if the brush or stylus cover are removed. If the distance between the stylus tip and the cartridge end is within 7 mm, use will be possible.
- Please enquire at your nearest authorized AIWA service center if the required adjustment cannot be made with the spacers provided.

# AIWACCO.,LTD.